

General Membrane
waterproofing systems

TECHNICAL SPECIFICATION

IMPRACTICABLE ROOF

B02

TOTALLY EXPOSED ROOF

WARM ROOF

MONOLITHIC CONCRETE

NEVER ENDING
NEW
WATERPROOFING

Date:		# Specifications:	
Purpose:	Impracticable roof - Totally exposed		# Code: B 02
Revision:			

Building site / project:	
Place:	
Surface:	

Client:	
Draughtsman:	
Building site supervisor:	
General Contractor:	
Specialized-installation company:	

M-26 - rev. 0 del 09/01/2013 – Heading - N.E.W. Specifications



Dear Professional,

General Membrane has developed a number of specifications aimed at supporting the design of the waterproof work. **The N.E.W. specifications** describe solutions for each type of roof; they contain the technical data of the products used, the regulations with which they comply and the laying methods in relation to the type of roof. In each specification proposal there are also exhaustive technical drawings of the project details.

The **N.E.W.** specifications are studied and developed according to an essential but often forgotten principle in the waterproofing of roofs: durability.

The life expectancy of at least **thirty years** of N.E.W. systems guarantees long-term economic savings to the benefit of environmental sustainability, as the materials used do not require premature replacement.

The heart of the N.E.W. systems is **Phoenix Super**, a bituminous membrane laid in a double layer.

"The Phoenix Super compound is created exclusively with APAO amorphous poly-alpha-olefines that are used to obtain a value of flexibility at low membrane temperatures of -35°C, even higher than that of the best SBS membranes.

This characteristic, which makes it easy to adapt the product during installation, remains unchanged over time. During testing, in fact, the low temperature flexibility of the PHOENIX SUPER membrane on new product was equal to -40°C, and after the thermal ageing test (84 d at 70°C) the value measured was equal to -35°C.

*The APAO -35°C compound is extremely resistant to the action of UV rays, thus characterising Phoenix Super as a **no-ageing** membrane, that is, insensitive to thermal ageing and long-term roofing functionality. A further advantage of the product is its high hot shape stability, superior to that of the best APP membranes."*¹

The durability of **Never Ending Waterproofing** systems is the result of the sum of the use of certified materials, with unique performances, with the offer of **substrate, monitoring and maintenance services**.

In particular, the good design of an impermeable work represents one of the most important phases in the creation of a durable roofing. This is why General Membrane develops the N.E.W. specifications offering its know-how in the design phase in compliance with what is stated in the **UNI** standard 8178 (*Building - Roofing - Analysis of the elements and functional layers*).

The N.E.W. proposal of General Membrane develops according to the directives of the standards:

- UNI 9307-1 which indicates the criteria for the design of each functional layer;
- UNI EN 8627 for the definition of compliant functional schemes;
- UNI 11345 which establishes the responsibilities of the various figures in execution of all the activities that result in the construction of a roof.

The company, with the N.E.W. systems, offers durable materials and technical support in the phases of:

- **Executive design:** through the drawing up of ad hoc **executive details**;
- **Installation:** through the **Installation Manual**, the installation check (**TAL**) and the consequent issuing of the **declaration of conformity** of the waterproof work;

¹ Taken from the document of the Institute for Construction Technologies, National Research Council "Technical Assessment Document for use no. DVT-0004 of 17.12.10".



- **Maintenance:** through the **maintenance manual** and the monitoring of the work over time, drawn up in compliance with the UNI EN 11540 standard.

The support process developed by General Membrane around the N.E.W. specification proposals finds its natural fulfilment in a twenty-year warranty which, in addition to covering the normal **Civil Liability** of the Company for the first 10 years from installation, covers the costs of **20 years** for regeneration of the stratigraphy due to product, installation and design defects.

For the purpose of activating the **twenty-year guarantee**, the project must be previously approved by General Membrane S.p.A. and activation will take place after **the installation has been checked** based on the initial project and the consequent issuing of the declaration of conformity.

General Membrane is also a member of the **U.S. Green Building Council**, confirming the Company's commitment to actively promoting the principles of sustainability. The development of sustainable architecture is therefore of primary importance for General Membrane which, through the N.E.W. specifications, proposes products that can contribute to granting **LEED credits (Leadership in Energy and Environmental Design)**.

The N.E.W. specifications comply with the current regulations regarding:

- **Building thermal and hygrometric performance:** The chapter solutions offered by General Membrane propose, where necessary, a thermo-insulating component that satisfies Italian **Legislative Decree 162 - 26 June 2015** to be sized with reference to the specific climatic zone and to the zone to which it belongs, always respecting the thermo-hygrometric balance of the roof according to the **UNI EN ISO 13788 standard**, with reference to the intended use of the underlying premises and to the external climatic conditions;
- **Wind extraction:** General Membrane, in the N.E.W. specifications, seeks to carry out the design of the wind extraction resistance of the solutions in complete exposure, performed in compliance with the **UNI EN 11442** and **UNI EN 16002 standards**;
- **Protection from external fire:** The General terms and conditions of General Membrane offer B-roof certified waterproof and thermo-waterproof proposals according to the **UNI EN 13501-5 standard**. The **B-roof** packs consist of bituminous membranes in **class E** according to the **UNI EN 13501-1 standard** and, where required, of class 1 thermal insulators according to the **UNI 8457** standard with self-extinguishing characteristics and low flammability.

The N.E.W. specification proposals also address the **Heat Island Effect**, providing solutions in line with the strategies of the International **EPA** centre (Environmental Protection Agency, U.S. body for environmental protection):

- **Solutions for green roofs:** **green** roofs contribute significantly to lowering the operating temperatures of the roofs, consequently reducing the phenomenon of heat islands in urban centres. The N.E.W. specifications include 4 **green roof** projects;
- **Solutions with reflective membranes or paints:** all the specifications in total exposure are proposed with exposed membranes surface protection system, conferred by the **Reflect Protection** white mineral coating technology or by the **Reflect Paint** white paints in order to reduce the roof temperature. All this translates into energy savings for the conditioning of buildings, promotes the dissipation of accumulated heat and keeps the membranes in an excellent condition.



Warm roof – Monolithic concrete

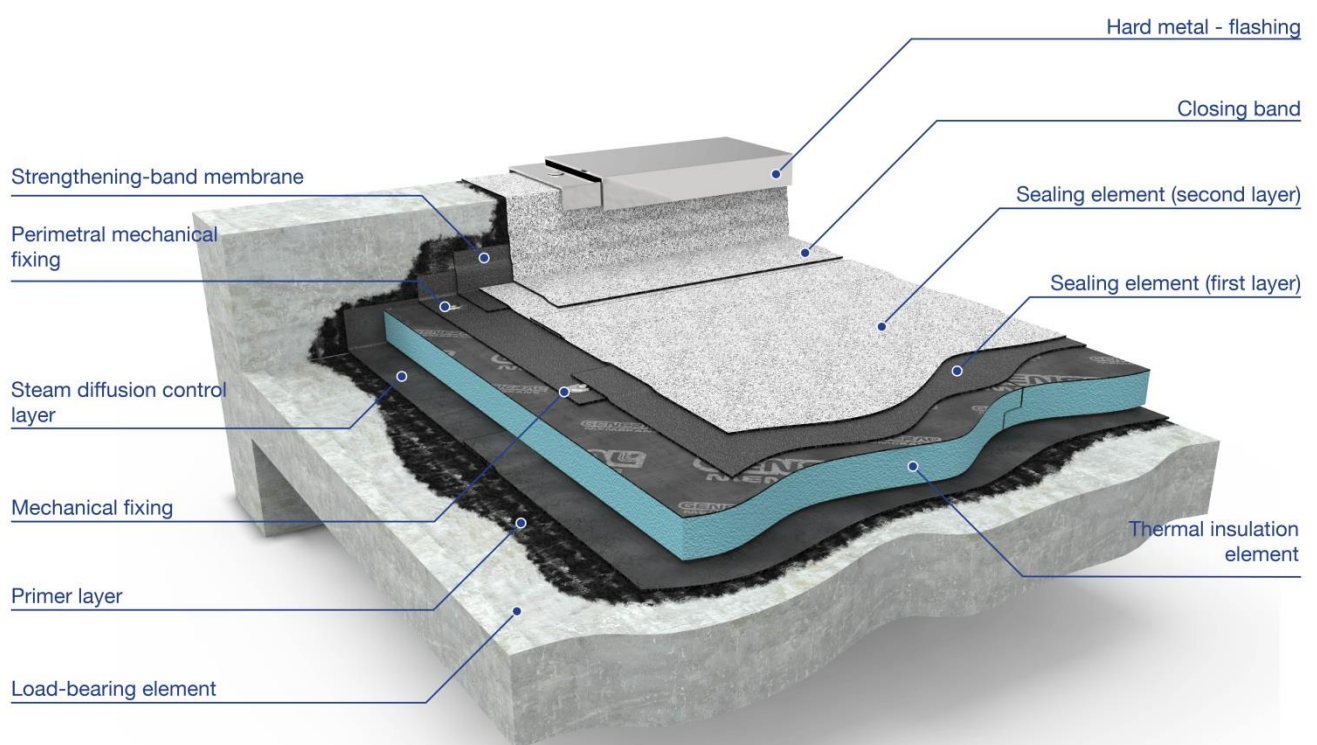

Stratigraphy

B 02

1. Load-Bearing element	5. Waterproofing element (1st layer)
2. Primer layer	6. Mechanical fixing
3. Control layer of steam diffusion	7. Waterproofing element (2nd layer)
4. Thermal-insulation	

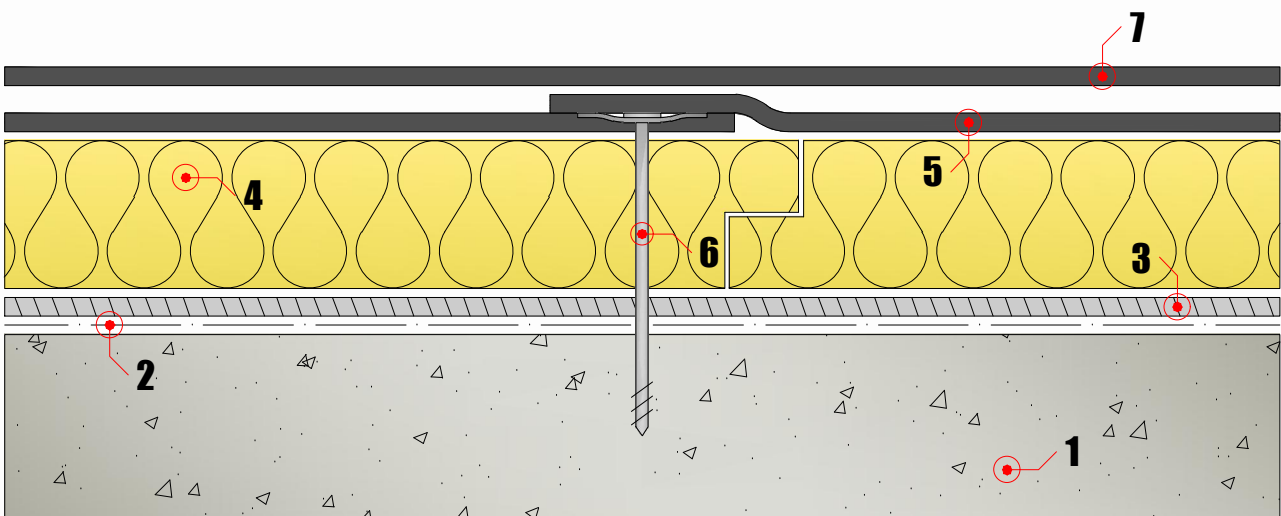

Summary specifications

Current section

1. Load-bearing element [↗](#)

Base substrate in monolithic concrete

Provided by you

2. Primer layer [↗](#)

Supply and installation of **General Eco Primer**

m²
€/m²

3. Steam diffusion control layer [↗](#)

Supply and installation of **Orion ALU VAP 3 mm/Orion VAP 3 mm**
Total adhesion installation

m²
€/m²

4. Thermal insulation element [↗](#)

Supply and installation **EPS**
Dry installation

m²
€/m²

5. Sealing element (first layer) [↗](#)

Supply and installation of **Phoenix Super 4 mm**
Laying in total adhesion assisted by mechanical fixing

m²
€/m²

6. Sealing element (second layer) [↗](#)

Supply and installation of **Phoenix Super Mineral Reflect Protection Broof (t2) 5.4 Kg/m²**
Total adhesion laying

m²
€/m²

System details and accessories

7. Vertical turn-ups [↗](#)

Connection of the waterproof system between the horizontal plane and the lateral containments

ml
€/ml



8. Elements for interstitial hygrometric control 

Vents for leakage of any interstitial condensates of the waterproof package.

pc.
€/pcs

9. Elements connecting to the vertical and horizontal downspouts 

Outlets connecting to the drain downspouts

pc.
€/pcs

10. Vertical crown elements 

Contour and crown flashings

ml
€/ml

11. Vertical turn-up on skylights 

Connection of the waterproof system to the skylights

ml
€/ml

12. Expansion joint 

Connection of the waterproofing system to the structural joints

ml
€/ml

13. Access thresholds 

Connection of the waterproof system to the access thresholds

ml
€/ml

14. Sectorisation 

Division into sectors of the waterproof stratigraphy

ml
€/ml

15. Possible elements to complete the roof 

Any additional elements that will be designed according to specific roof requirements



Descriptive specifications

Current section

(Detail B02)

1. Load-bearing element

Base substrate in monolithic concrete of adequate consistency (minimum resistance RCK 250 kg/cm²) suitable to receive any mechanical fasteners. The substrate, if considered a flat roof (up to 5° of inclination) must have a minimum slope requirement for rainwater run-off (1.5%). It must also be planar, without unevenness, very cohesive, dry and clean, with suitable surface roughness appropriate to accommodate the waterproof stratigraphy.

Technical note:

All intersections between the plane and vertical must be adequately prepared with mortar shells, of adequate consistency with a guarantee of resistance over time, to avoid abnormal stresses of the bituminous waterproofing stratigraphies.

In anticipation of the Total adhesion installation of bituminous membranes, to guarantee improved adhesion to the base substrate, on all surfaces where the impermeable stratigraphy will subsequently be laid, a layer of bituminous primer such as **General Eco Primer will be applied**.

Provided by you

2. Primer layer

Supply and installation of **General Eco Primer**

Bituminous primer based on bitumen in aqueous emulsion and additives, solvent-free, having the function of modifying the surface physical-chemical characteristics of the substrate in order to promote cortical consolidation and adhesion of the elements or upper layers. General Eco Primer is free from any type of solvent. It is therefore not harmful. The water base prevents the risk of flammability.

The product has a VOC content of 385 g/l which satisfies the characteristics of the IEQ 4.1 credit requirements of the **LEED** protocol, an evaluation system of the eco-sustainability of buildings developed by **Green Building Council**.

The product must comply with the following minimum values reported in the declaration of performance :

Volume density 20°C

0.90-1.00 Kg/cm³

Viscosity at 20°C

20-25" DIN 4

Dust-dry drying time at 20°C

240 - 360 min

Depth drying time

360 - 480 min

Flash point

Non-flammable



- **Installation**

The primer will be created using a roller, a brush or an airless spray (a nozzle with a 0.5 mm ø at 150 atm) across the entire surface, spreading a layer to the extent of 0.150/0.300 kg/m².

Technical notes:

Before the surface priming works, an adhesion test will be performed with two portions of the membrane making them adhere to the substrate, the first on a primed part and the second on an area without primer. Subsequently a peeling test will be performed and use of the primer layer will be evaluated according to the adherence found.

It is important that the surfaces to be painted are as dry as possible, free from oils or dusty powders. The primer must penetrate into the cementitious surface fixing the dust, but must never create a continuous film. The visual presence of different coloured patches is not a sign of insufficient conformity.

m²
€/m²

3. Vapour diffusion control layer

Technical note:

The choice of using a brake or a steam barrier must be studied according to the thermo-hygrometric calculation of the roof according to the **UNI EN ISO 13788 standard** (*Hygrothermal performance of components and building elements - Internal surface temperature to avoid critical surface humidity and interstitial condensation - Calculation method*) in relation to the intended use of the premises covered by the roof and to the climatic conditions of the area where it is located.

We remind you that compliance with the minimum thermal insulation values does not guarantee the hygrometric balance of the roof. Therefore refer to the verification to check the calculation values.

a) Steam barrier

Supply and installation of **Orion ALU VAP 3 mm**

Prefabricated bituminous waterproofing membrane based on bitumen modified with elastoplastic polymers, triple reinforcement with non-woven polyester fabric stabilised with glass, glass fibre and aluminium sheet, 3 mm thick, Orion type. The product has a characteristic of flexibility at low temperatures of **-15°C** according to **UNI EN 1109** and hot form stability of **130°C** according to **UNI EN 1110**.

The membrane has CE marking according to the directives specified in the **UNI EN 13970 standard** (*Flexible membranes for waterproofing - Bituminous layers for the control of water vapour - Definitions and characteristics*) for the precise intended use as a steam barrier and must respect the following minimum values reported in the declaration of performance:

Coefficient of resistance to the passage of steam:

UNI EN 1931 **1.250.000 μ**

UNI EN 12317-1 **400/250 N/50mm ± 20%**

Maximum load long./transv. tensile strength:

UNI EN 12311-1 **450/270 N/50mm ± 20%**

Maximum load long./transv. connections tensile strength:



Long./transv. break elongation:
UNI EN 12311-1 **20/25%** - 15% absolute

Long./transv. dimensional stability:
UNI EN 1107-1 met. A $\pm 0.3\%$
minimum value

Long./transv. tear resistance:
UNI EN 12310-1 **150/150 N** -30%

b) Steam brake

Supply and installation of **Orion VAP 3 mm**

Prefabricated bituminous waterproofing membrane based on bitumen modified with elastoplastomeric polymers, reinforced with polyester non-woven fabric stabilised with glass, 3 mm thick, Orion type. The product has a characteristic of flexibility at low temperatures of **-15°C** according to **UNI EN 1109** and hot form stability of **130°C** according to **UNI EN 1110**.

The membrane has CE marking according to the directives specified in the **UNI EN 13970 standard** (*Flexible membranes for waterproofing - Bituminous layers for the control of water vapour - Definitions and characteristics*) for the precise intended use as a vapour brake and must respect the following minimum values reported in the declaration of performance:

Coefficient of resistance to the passage of steam:
UNI EN 1931 **110,000 μ**

Long./transv. break elongation:
UNI EN 12311-1 **35/35%** -15% absolute

Maximum load long./transv. connections tensile strength:
UNI EN 12317-1 **400/300 N/50mm** $\pm 20\%$

Long./transv. tear resistance:
UNI EN 12310-1 **140/140 N** -30%

Maximum load long./transv. tensile strength:
UNI EN 12311-1 **500/400 N/50mm** $\pm 20\%$

Long./transv. dimensional stability:
UNI EN 1107-1 met. A $\pm 0.3\%$
minimum value

- **Total adhesion installation**

The steam/brake barrier will be laid in full adherence by means of a propane gas flame on the receiving surface, after suitable preparation if necessary and priming of the substrate, with longitudinal offset of the sheets.

The membrane will be turned up on the vertical reliefs overcoming the height of the thermal insulation element, as described in the specific detail item. The longitudinal overlaps will be heat sealed in total adhesion by a propane gas flame for at least 10 cm and the head ones by at least 15 cm. The "T" intersections between multiple sheets must provide a 45° chamfer in the corners of the membrane receiving the overlap.

Technical note:

In heat sealing of the continuity overlaps it will be necessary to operate in such a way as to create the uniform outlet of a melted compound joint seal, an indicator of sealing and correct heat sealing at the points of membrane overlap. The membrane, laid in total adhesion on the substrate and turned up on the vertical reliefs as described in the specific detail item, will guarantee the temporary "outflow of water".

The operations will be performed with laying according to a professional standard referred to by the **UNI EN 11333 standard** (*Laying of flexible membranes for waterproofing*).

m²
€/m²



4. Thermal insulation element

Supply and installation of **EPS**

Technical sheet in high density sintered expanded polystyrene, moulded (with closed cells also on the surface), without adding external foaming agents, with declared conductivity $\lambda_D = \dots$ W/mK, with dimensions... x... mm and thickness (of... mm) according to the specific climatic zone, respecting the legal limits in force and according to the **UNI/TS 11300 standard** (*energy performance of buildings*). The heat-insulating element has a characteristic compressive strength... kPa.

The panel will be pre-coupled with a solution of continuity to a 2 mm thick bitumen polymer membrane reinforced with glass film that is able to accommodate the total adhesion laying of the subsequent impermeable layers, also preserving the physical-mechanical characteristics of the thermal insulation element.

Technical note:

The thermal insulation component must meet the minimum values of thermal insulation dictated by **Italian Legislative Decree 29 December 2006, no. 311** on the energy performance of buildings, with reference to the specific climatic zone and to the zone to which they belong.

Thermal transmittance of horizontal or inclined opaque structures:

Table 3.1	Roofs (U limit in W/m ² K) - Legal limits
Climate zone	From 1 July 2015
A	0.38
B	0.38
C	0.36
D	0.30
E	0.25
F	0.23

A modelling of the thermal properties of the building is also recommended, as established by the requirements of the EA 1 credit, for an assessment of the thermal performance of the entire building envelope and for the allocation of credits if the building is subject to the **LEED** protocol, evaluation system of the eco-sustainability of buildings developed by the **Green Building Council**.

The panel has CE marking according to the directives specified in the **UNI EN 13163 standard** (*Thermal insulation products for buildings - Factory made polystyrene foam products (EPS) - Specification*) with reference to the precise intended use as a thermal insulating element and must respect the following minimum values reported in the declaration of performance:

Declared thermal conductivity determined at the average temperature of 10°C:
UNI EN 12939 ... λ_D (W/mK)

Factor of resistance to the diffusion of water vapour:
UNI EN 12086 ... $\mu \pm \dots$

Linear thermal expansion coefficient
UNI 6348 ... K^{-1}

Water absorption - total immersion test for 365 days:
UNI EN 12087 ...% own weight



- **Dry installation**

The panel will be laid dry on the receiving surface and distributed in a longitudinally staggered pattern with respect to the longer side, being sure to pull the flattened sides together to avoid thermal bridges.

m²
€/m²

5. Sealing element (first layer)

Supply and installation of **Phoenix Super 4 mm**

Bituminous prefabricated waterproofing membrane based on bitumen modified with amorphous poly- α -olefin (APAO) reinforced with non-woven polyester fabric with continuous wire stabilised with a thickness of 4mm, Phoenix Super type. The membrane has a characteristic of flexibility at low temperatures of **-35°C** both from new and after ageing for 6 months at 70°C according to **UNI EN 1296/UNI EN 1109** and hot shape stability, with the same principle, of **140 °C** according to **UNI EN 1296/UNI EN 1110**.

The membrane ensures its qualities with the control over time through external certification of **ITC-CNR** (*Institute for Construction Technologies - National Research Council*) and **BBA** (*British Board of Agrément*), guaranteeing the durability and maintenance characteristics of the physical-mechanical properties over time, certified by **Agrément DVT certifications no. 0004/10** (former I.C.I.T.E. no. 610/03) and **BBA Agrément Certificate no. 99/3586**.

Phoenix Super has characteristics of reaction to fire in **class E** according to **UNI EN 13501-1** (*Fire classification of products and building elements - Part 1: Classification based on the results of fire reaction tests*).

The membrane has CE marking according to the directives specified in the **UNI EN 13707 standard** (*Flexible membranes for waterproofing - Bituminous membranes reinforced for the waterproofing of roofs - Definitions and characteristics*) for the precise intended use as a sealing element and must comply with the following minimum values reported in the declaration of performance:

Maximum load long./transv. connections
tensile strength:
UNI EN 12317-1 **500 / 500 N/50mm**
minimum value

temperature and water:
UNI EN 1297/UNI EN 1850-1
test passed

Maximum load long./transv. tensile strength:
UNI EN 12311-1 **900/650 N/50mm** $\pm 20\%$

Reaction to fire:
UNI EN 13501-1 **class E**

Long./transv. break elongation:
UNI EN 12311-1 **40/45%** ± 2 absolute

Fatigue cycles test (stress simulation on the
insulating panel alignment line or on
discontinuous base substrates):
EOTA TR 0088 test for 1500 cycles
test passed

Long./transv. tear resistance:
UNI EN 12310-1 **200/200 N** -30N

Long./transv. dimensional stability:
UNI EN 1107-1 met. At $\pm 0.3\%$ maximum
value

Artificial ageing through long-term exposure
to the combination of UV radiation, high



- **Installation in total adhesion assisted by mechanical fixing**

The membrane will be laid in total adhesion by means of a propane gas flame on the receiving surface, after suitable preparation if necessary, with longitudinal offset of the sheets. Furthermore, it will be secured to the base substrate by a mechanical fixing system at the overlaps, to an adequate extent, in relation to extraction of the wind that acts on the specific roof.

Technical note:

The mechanical fixing will be quantified according to the design, for the specific roofing, of the wind extraction resistance performed in compliance with the **UNI EN 11442 standard** (*Criteria for the design of the continuous roofing wind resistance*) by evaluating the wind extraction resistance of the mechanically fixed system according to **UNI EN 16002** (*Flexible membranes for waterproofing - Determination of wind load resistance of mechanically fixed flexible membranes for roof waterproofing*).

The mechanical fixing will be intensified along all the perimeters, skylights, chimneys and openings present in the roof. The attachment will be performed using automatic or manual tools.

Fixing accessories:

- Fastening elements made with stop plugs/self-tapping screws suitable for the thickness to be locked.
- Anchoring plates in steel sheet/polypropylene sleeves.

The membrane must be turned upside down along the vertical walls as described in the specific detail item. The longitudinal overlaps will be heat sealed in total adhesion by a propane gas flame for at least 10 cm and the head ones by at least 15 cm. The "T" intersections between multiple sheets must provide a 45° chamfer in the corners of the membrane receiving the overlap.

Technical note:

In heat sealing of the continuity overlaps it will be necessary to operate in such a way as to create the uniform outlet of a melted compound joint seal, an indicator of sealing and correct heat sealing at the points of membrane overlap.

The operations will be performed with laying according to a professional standard referred to by the **UNI EN 11333 standard** (*Laying of flexible membranes for waterproofing*).

m²
€/m²

6. Sealing element (second layer)

Supply and installation of **Phoenix Super Mineral Reflect Protection Broof (t2)** 5.4 Kg/m²

Bituminous prefabricated waterproofing membrane based on bitumen modified with poly- α -olefin amorphous (APAO), reinforced with non-woven polyester fabric resistant to continuous wire stabilised with glass, weighing 5.4 Kg/m², type Phoenix Super. The membrane has a characteristic of flexibility at low temperatures of -35°C both from new and after ageing for 6 months at 70°C according to **UNI EN 1296/UNI EN 1109** and hot shape stability, with the same principle, of 140 °C according to **UNI EN 1296/UNI EN 1110**.

The membrane ensures its qualities with the control over time through external certification of **ITC-CNR** (*Institute for Construction Technologies - National Research Council*) and **BBA** (*British Board of Agrément*), guaranteeing the durability and maintenance characteristics of the physical-mechanical properties over time, certified by **Agrément DVT certifications no. 0004/10** (former I.C.I.T.E. no. 610/03) and **BBA Agrément Certificate no. 99/3586**.



Phoenix Super has characteristics of reaction to fire in **class E** according to **UNI EN 13501-1** (*Fire classification of products and building elements - Part 1: Classification based on the results of fire reaction tests*).

The waterproof sealing element contributes, together with the other functional layers, to attributing characteristics of behaviour to external fire **Broof (t2)** to the roof pack according to **UNI EN 13501-5** (*Fire classification of products and building elements - Part 5: Classification based on the results of tests of roof exposure to an external fire*).

The membrane will have a surface finish with mineral protection in white slate flakes. **Reflect Protection**, which will give an **SRI** of 80% according to **ASTM-E1980**, reducing the temperature of the waterproofing membrane with a consequent energy saving for the conditioning of the buildings, promoting dissipation of the accumulated heat and reducing the phenomenon of heat islands in accordance with the credits SS 7.1 and SS 7.2 of the **LEED** protocols.

The membrane has CE marking according to the directives specified in the **UNI EN 13707 standard** (*Flexible membranes for waterproofing - Bituminous membranes reinforced for the waterproofing of roofs - Definitions and characteristics*) for the precise intended use as a sealing element and must comply with the following minimum values reported in the declaration of performance:

Maximum load long./transv. connections
tensile strength:
UNI EN 12317-1 **500 / 500 N/50mm**
minimum value

Reaction to fire:
UNI EN 13501-1 **class E**

Maximum load long./transv. tensile strength:
UNI EN 12311-1 **900/650 N/50mm ± 20%**

Long./transv. break elongation:
UNI EN 12311-1 **40/45± 15%** absolute

Long./transv. tear resistance:
UNI EN 12310-1 **200 / 200 N -30 N**

Long./transv. dimensional stability:
UNI EN 1107-1 met. At **± 0.3%** minimum
value

Technical note:

As an alternative to the **Phoenix Super Reflect Protection granulated** membrane, a second **Super Phoenix** 4 mm sealing layer can be provided, on which a special white ceramic coating with surface protection with very high reflecting power, such as **General Reflect Paint PLUS**, will be applied, which will confer an **SRI** of 80% according to **ASTM-E1980**, reducing the temperature of the waterproofing membrane with consequent energy saving for conditioning of the buildings, promoting dissipation of the accumulated heat and reducing the phenomenon of heat islands in accordance with the credits SS 7.1 and SS 7.2 of the **LEED** protocols.

- **Total adhesion installation**

The membrane will be laid in total adhesion by propane gas flame to the first impermeable layer, with longitudinal offset of the sheets. Furthermore, it must be offset both longitudinally and transversely with respect to the first sealed layer.



The membrane must be turned upside down along the vertical walls as described in the specific detail item. The longitudinal overlaps will be heat sealed in total adhesion by a propane gas flame for at least 10 cm and the head ones by at least 15 cm. The "T" intersections between multiple sheets must provide a 45° chamfer in the corners of the membrane receiving the overlap.

Heat sealing of the overlapping of the membrane heads with mineral protection must take place after heating the underlying slate to incorporate the mineral granules in the thickness of the waterproofing mass.

Technical note:

In heat sealing of the continuity overlaps it will be necessary to operate in such a way as to create the uniform outlet of a melted compound joint seal, an indicator of sealing and correct heat sealing at the points of membrane overlap.

The operations will be performed with laying according to a professional standard referred to by the **UNI EN 11333 standard** (*Laying of flexible membranes for waterproofing*).

m²
€/m²



Dettagli ed accessori del sistema

7. Vertical turn ups

(detail B02/1)

The steam diffusion control layer must be turned up and laid in total adhesion by means of a propane gas flame on the vertical elevation exceeding the level of the thermal insulation element, after priming of the area concerned using primers as described in the specific item, thus ensuring the temporary site "outflow of water".

After laying the thermal insulating panel, the layer constituting the first sealing element must be turned up to a minimum height necessary to achieve sealing with the appropriate steam barrier/brake, thus ensuring a new temporary "water outlet". A perimetric mechanical fixing will therefore be provided which will connect all the functional layers so far described to the base substrate. At the same time, a strip of membrane laid in total adhesion by means of a propane gas flame must seal the corner, adhering to the first sealing element coming from the horizontal plane and rising to a minimum height of at least 15 cm, always ensuring the hydraulic seal.

Using the same criterion the next step is laying of the second sealing element, this time up to the wall, without performing any turn-up. A subsequent strip will cover the vertical elevation for a minimum height such as to exceed by at least 10 cm the height of the first strip, adhering to the wall and turning up for at least 15/20 cm on the heads and on the longitudinal sides of the sealing element placed on the horizontal roof plane.

An insulating panel with a precise mechanical protection function will be placed behind the perimeter vertical during installation and maintenance of the roof garden. Both the protection, separation, sliding and drainage layer and the filtering layer will rise on the vertical for a minimum height useful to keep the sealing elements protected from the clay and from the gravel edge that will be provided along the entire perimeter of the roof.

The described vertical turn-up system is coherent with what is prescribed and designed in the executive details of the **UNI EN 11333-2 standard** (*Laying of flexible membranes for waterproofing*).

Complete closure of the perimeter will be guaranteed by adequate vertical crown elements, as described in the specific detail item.

Furthermore, the internal and external corners must be created by adhesion, joint heat sealing and features in compliance with what is prescribed and designed in the executive details of the **UNI EN 11333-2 standard** (*Laying of flexible membranes for waterproofing*).

Technical notes:

For appropriate sealing of the vertical elevations it is forbidden to create the membrane flap, with a continuity solution, using the sheets coming from the horizontal roof plane. The strips constituting the vertical seal will be created by cutting portions of membrane in a transverse direction with respect to the length of the sheet, with a maximum width equal to the size of the sheet (generally 100 cm), which may eventually increase up to 250 cm if the laying, always in total adhesion with a propane gas flame, is performed simultaneously by 2 operators.

ml
€/ml



8. Elements for interstitial hygrometric control (detail B02/2)

On the flat surface of the roof, vents will be placed evenly distributed in conical prefabricated sections, in the ratio of 1 pc/25-30 m², compatible with the described waterproofing and of suitable height depending on the type of use of the roof. They will be included as a preventive measure in order to guarantee the possible evacuation of the water vapour that can accumulate inside the waterproofing pack, thus avoiding the creation of interstitial condensates due to possible thermo-hygrometric design errors or residues of internal humidity that have accumulated during the works or in the materials present in the stratigraphy. The aerators can be single or with a double coaxial body, depending on the need to evacuate only the steam from the extrados of the thermally insulating element or even below the envisaged steam control layer.

The individual vent flues will be placed dry above the thermal insulation panel. The aerators must be secured by means of adequate mechanical fasteners to the base substrate, at a rate of 3 pcs/aerator, subject to the interposition of the first impermeable layer and its flame heat sealing on the flanges. The second layer constituting the sealing element will be laid in total adhesion to the first. Complete sealing of the vent will be ensured by a piece of membrane that will penetrate the aerator's section until it settles and to be laid in total adhesion on the extrados of the waterproof system and, with the same procedure, on the height of the conical section of the vent. The membrane pieces will be perforated by cross-cutting performed on site or they can be supplied with prefabricated central die. A further closure will be guaranteed by the laying of a metal strap which will, in its vertical part, secure the piece of membrane close to the aerator's section.

The creation of coaxial double-body vents must provide for the laying of the connection cone located below the barrier/steam brake layer.

Technical note:

In cases where there is a high criticality of formation of internal condensates due to conditions of particular intended use of the underlying premises, or for a simple design choice, it will be possible to increase the aeration capacity of the aerator for the evacuation of any interstitial condensate by using a particular double-cone terminal to guarantee a continuous suction force induced by the action of the wind.

pc.
€/pcs

9. Elements connecting to the vertical and horizontal downspouts (detail B02/3, B02/4 and B02/6)

Connection to the descending downspouts will be created with prefabricated rigid drain outlets, compatible with the described waterproofing, of diameter and length of the shank suitable for connection to the descending elements present in the structure. They must be provided in such a number as to ensure a safe run-off of the rainwater from the roof.

The planar and corner outlets must be consistently placed at the lowest points of the roof and, if possible, the slot into which they are placed must be lower with respect to the laying plane to facilitate water disposal. The drains will be placed over the first impermeable layer. They must be secured by means of adequate mechanical fasteners to the base substrate, at a rate of 3pc/outlet. The second layer constituting the sealing element must be shaped and heat sealed inside the cone of the discharge outlet.



Before laying the drainage layer, grating covers must be provided, previously placed above the drain outlets, which will delimit the areas where the clay has fallen and of the next cultivation earth, avoiding obstructing the downspouts and compromising correct disposal of the rainwater from the roof.

The "overflow" drains will be created, with the same criterion, on the vertical elevations of the perimeters at a height of approximately 10/15 cm with respect to the horizontal planar height.

The outlets will be provided, depending on the intended use of the roof, with "spider" leaf guard or interlocking gravel guard, including fins to prevent them from escaping from the funnel.

Technical notes:

In areas with a high rainfall index, if there is concern for regurgitation, it is advisable to use downspouts with cup connection fitted with an "o-ring" sealing ring on which the shank of the drain outlet is inserted, thus avoiding phenomena of overflow of the downpipe inside the buildings.

If the provisional nature of the water outflow guaranteed by the vapour barrier/brake should last for long periods, it is advisable to insert an additional outlet to the descending downspouts which will be connected coaxially to the upper pipe union located under the second sealing element.

pc.
€/pcs

10. Vertical crown elements

(detail B02/5)

Contour and crown flashings of vertical reliefs sealed against air and water and appropriately shaped according to site requirements dictated by the configuration of the type of vertical turn up. The nature of the material, the thickness and colours are chosen by the Director of Works.

ml
€/ml

11. Vertical turn up on skylights

(detail B02/7)

The sealing elements must be raised in a similar manner to that described in the detail item of the perimeter verticals, turning up the closing strip until the vertical head is completely covered. At its summit, the skylight bracket will be mechanically secured, following interposition of the windproof band in compressible material (polyethylene or reticular polypropylenes).

ml
€/ml

12. Expansion joints

(detail B02/8)

All structural joints must be adequately sealed with a continuity solution, being sure to maintain appropriate membrane excesses to avoid tensioning of the sealing elements at the intersection points, caused by the dilator movements of the prefabricated elements.

A membrane strip will be laid in total adhesion along the intersection lines, connecting the sealing element constituting the first impermeable layer coming from the adjacent elements. The creation of this bridging must be performed being sure to maintain a suitable excess between the two prefabricated elements, however minimal to be able to accommodate a compressible flexible tube inside it. Subsequently, the second layer of waterproofing will be applied, which will end



close to the compressible element. At its extrados, a sealing strip will be laid in total adhesion, completing sealing along the structural joint.

Technical note:

The choice of using technical detail does not exempt the designer/Director of Works from evaluating the effective efficiency of this detail in relation to the calculation of movement of the structural joint.

ml
€/ml

13. Access thresholds
(detail B02/9)

Generally speaking, the thresholds must be set in place, with no exceptions, only and exclusively after laying subthreshold waterproofing. Conceptually, depending on the configuration and on the type of sub-threshold structural works, the membranes with waterproof sealing function must turn up in all vertical confinements with respect to the laying level of the threshold. The height of the overlaps must always be higher than the sliding plane of the sealing element.

The sub-threshold waterproofing will be connected to the sealing layers coming from the horizontal plane by means of installation in total adhesion with a propane gas flame. The membranes must be laid on the entire laying plane of the access door thresholds and tilted on the vertical elevations for a height of at least 20 cm.

Technical note:

If, for time reasons, a door threshold is laid before the waterproof stratigraphy, the sub door threshold waterproofing will in any case be laid before the door threshold itself leaving a wide area for its subsequent attachment to the sealing elements, located on the horizontal plane of the roof.

Particular attention is required to avoid damaging the sub door threshold during the laying operations, using for anchoring of the same door threshold materials that are compatible with the sealing element (sand beds, mortar, glues, etc.), or any materials that are free from organic and solvent substances.

ml
€/ml

14. Sectorisation
(detail B02/10)

During the installation of the current section, a hermetic connection will be created between the sealing element constituting the first waterproof layer and the bituminous steam barrier/brake, placed in total adhesion to the base substrate, with the creation of a reduced and confined sealing roof sector. The connection will be made by turning the first impermeable layer downwards with respect to the insulating panel and heat sealed with a continuity solution with propane gas flame to the laying surface or to the steam diffusion control element placed on the horizontal plane for approximately 15 cm. Localisation of the sectorisation will be identified by the specialist installation company on the relevant plan issued by the Director of Works, configured respecting the rainwater run-off. In general, the sectorisation will be located at the maximum slope levels and will be closed near the minimum altitudes at the descending downspouts. The current section of the waterproof system will start with the base stratigraphy close to the vertical part created by the confinement, and will then descend again to the next sectorisation line.



Technical note:

The division into sectors (partitioning or sectorisation) is the practice that in "hot" and "sandwich" roofs creates a hermetic seal of the first waterproof sealing layer with the bituminous steam barrier in total adhesion to the base substrate, the purpose of which is to limit the extent of damage in the event of localised waterproofing defects due to incorrect laying or damage of third parties. In relation to the complexity of the possible removability of the layers above the sealing element, the sectorisation practice will be fairly large depending on the intended use:

Roofs in full exposure/simple = large surfaces 500/600 m²

The layout of the sectors must, in its design, take into account the rainwater run-off system and must be located at the highest points of displacement of the base substrate slopes.

The designer will have to modulate the size of the sector according to the type of roof and will have to draw up a precise sector plan to be made available to the specialist installation company during construction and then as "as-built" (with any changes made to the original project) to be made available in the work file for future extraordinary maintenance if necessary.

The division into sectors is an important safety factor. It is essential not only for partitioning of the roof into smaller areas, when it may be necessary to search for defects, but also for the confining of roof areas with particular intended uses (air treatment systems or other appliances). Furthermore, the sector allows daily planning of the waterproof work to be carried out with an objective of a pre-set evening seal to prevent any nocturnal atmospheric events from infiltrating dangerously into the incomplete stratigraphy. Finally it offers an emergency closure, during waterproof operations, for sudden changes of climatic conditions that could compromise waterproofing of the structure.

The sectorisation practice is preferably combined with fairly sophisticated control devices which, in addition to constituting the highest technological level for the waterproofing of flat roofs, instantly identify leaks in the sealed layer (ampoules placed at the lowest point in the sector) or even indicate abnormal changes in humidity within the sector (sensors within the stratigraphy that via wireless communicate with a remote monitoring software). This practice is very useful for identifying damage caused by third parties during various operations above the waterproof stratigraphy, or is a useful tool for the Director of Works for the preparation of test reports and for delivery of the finished waterproof work.

Optional notes:

In the sectors it will be possible to insert, at the minimum dimensions, near the descending downspouts, dedicated ampoules that can be inspected on the intrados of the base substrate that will highlight any losses of the sector. When the waterproofing is completed, the absence of water in the cups will validate testing of the sector by the Director of Works.

In the sectors, depending on the size, humidity sensors can be connected to a dedicated control unit on the extrados of the stratigraphy, which will send wireless signals remotely to the operating system monitored by the Director of Works and subsequently by the customer. Stabilisation of the relative internal humidity of the waterproof pack, once completed, will allow the drafting of a specific inspection report of the sealed sector.

ml
€/ml

15. Possible elements to complete the roof

To complete this specification, in relation to the specific needs of the roof, the executive details relating to any works not contemplated will be designed.



Vertical walls

B 02/1

1. Perimetral mechanical fixing

3. Sealing-band membrane

2. Strengthening-band membrane

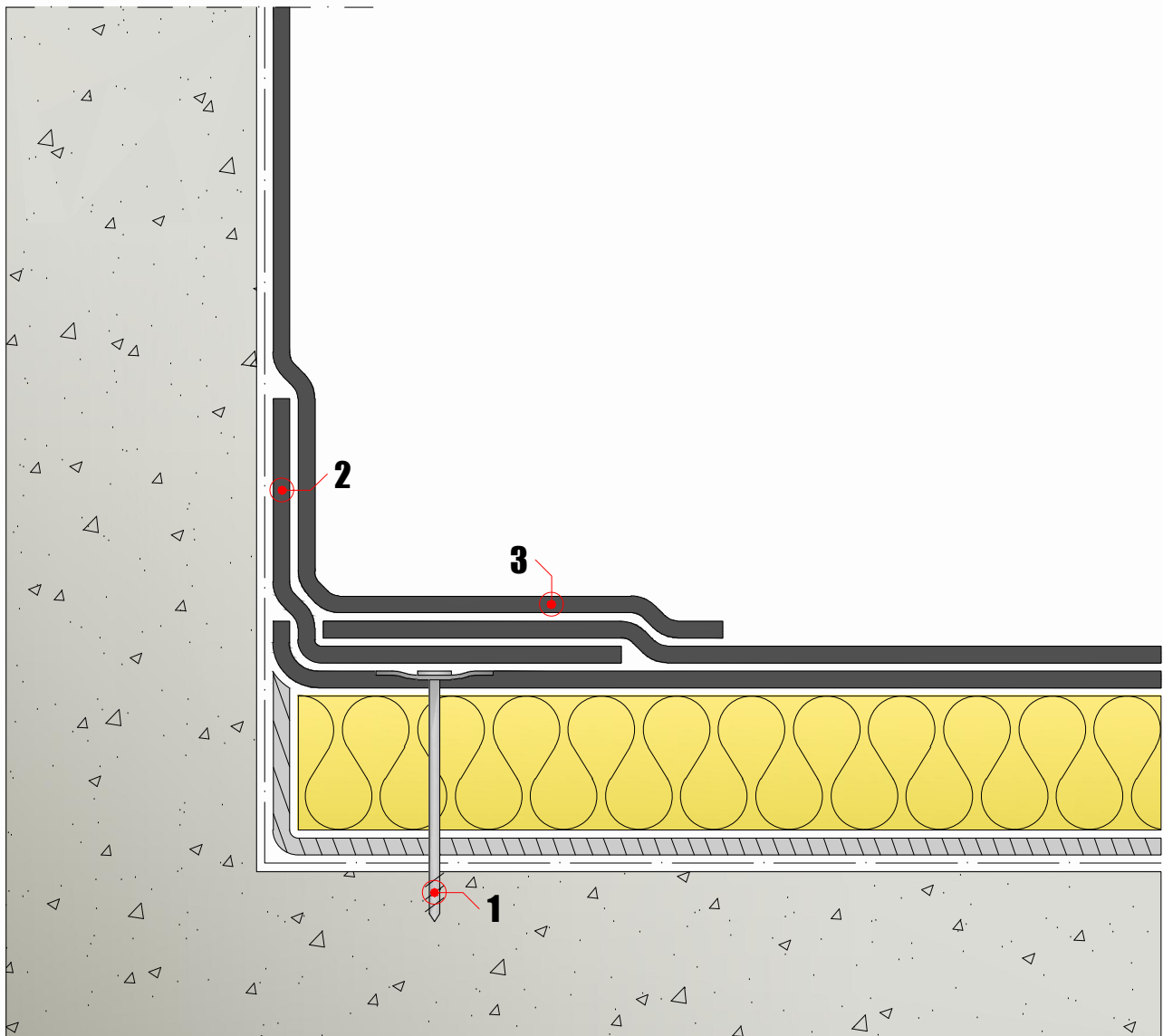

Vents

B 02/2

1. Air vent

3. Piece of membrane

2. Mechanical fixing

4. Metallic strap

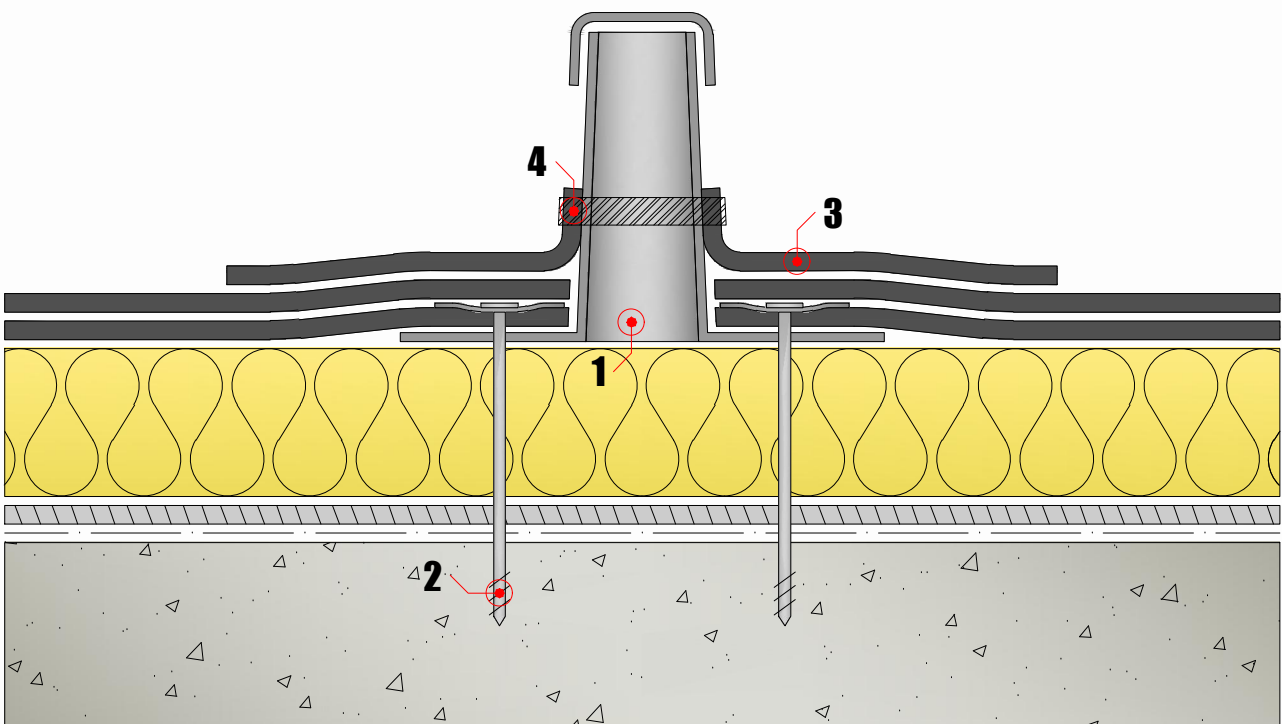

Drains

B 02/3

1. Pluvial

3. Mechanical fixing

2. Drain

4. Leaf-Guard

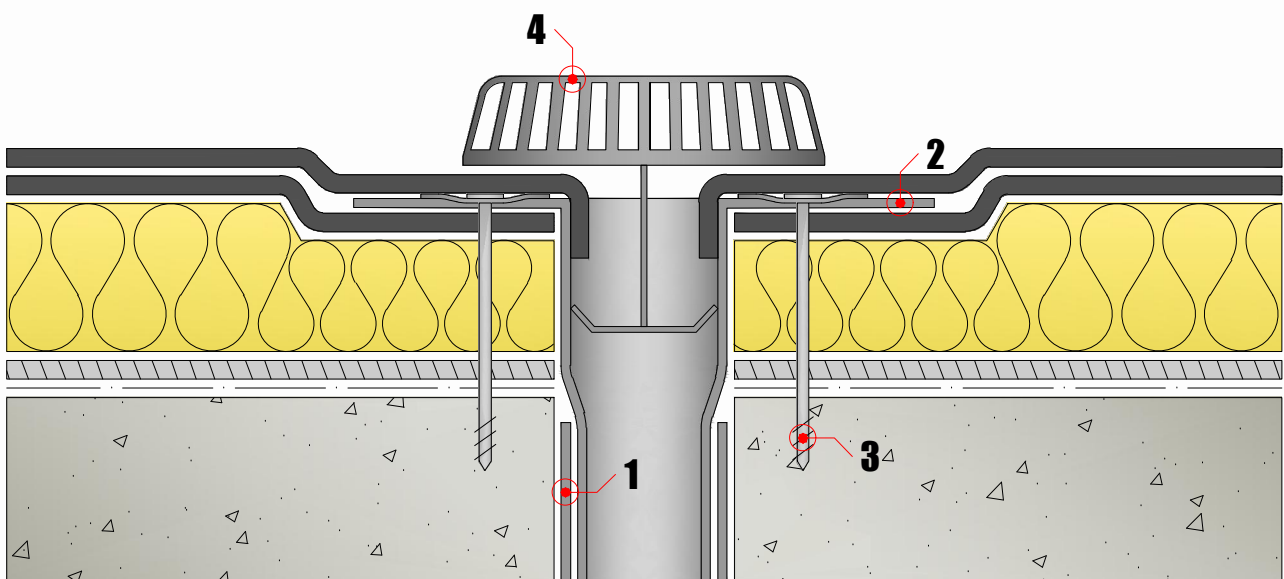

Angular drains

B 02/4

1. Angular drain

3. Leaf-Guard

2. Mechanical fixing

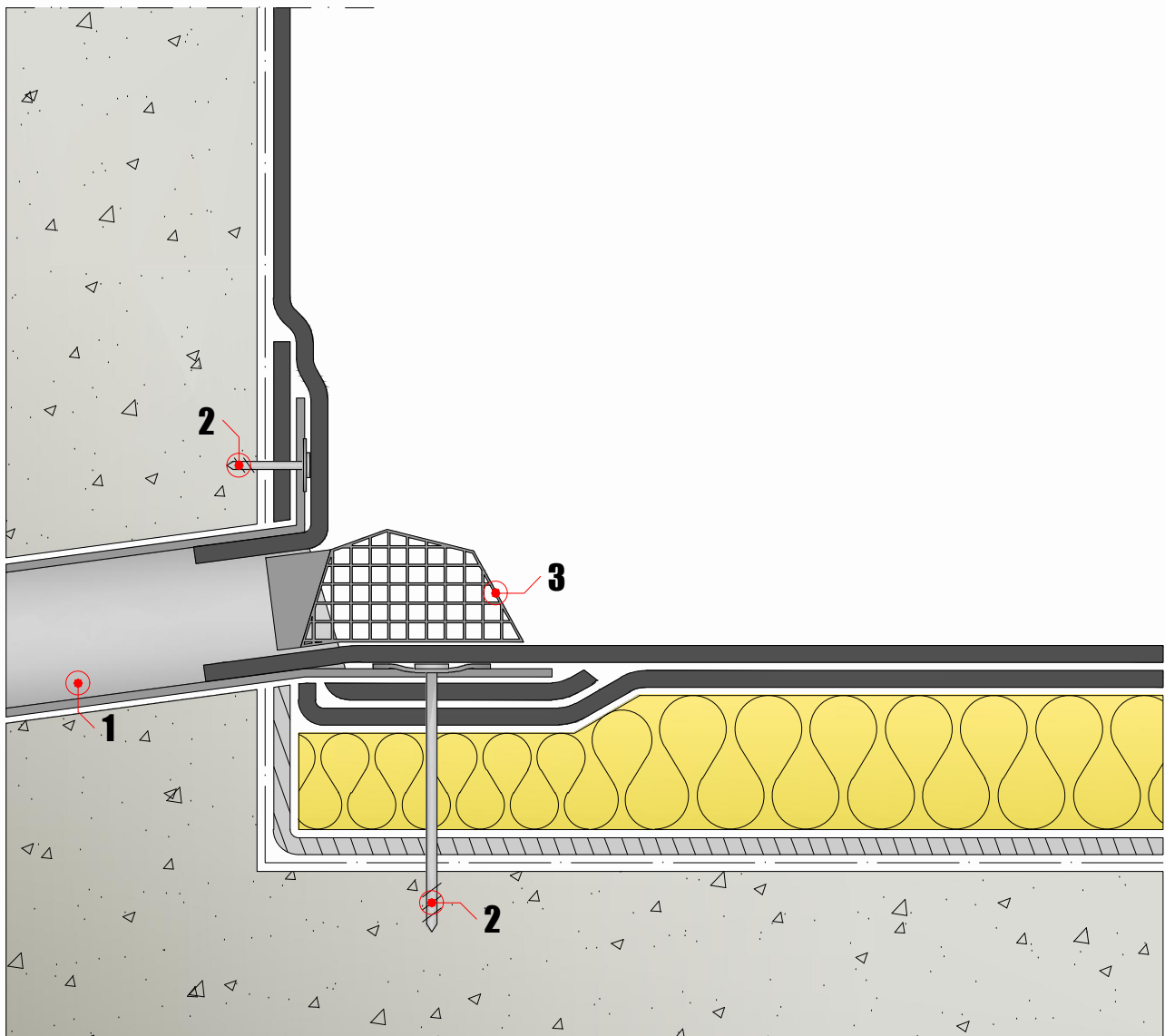

Vertical crowing elements

B 02/5

1. Vertical metal-flashing

4. Head metal-flashing

2. Mechanical fixing

5. Mechanical fixing

3. Sealing

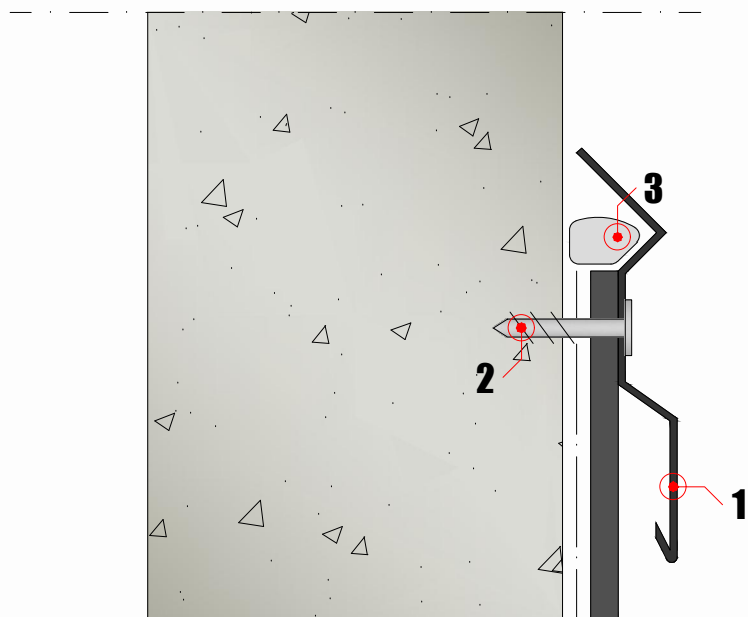
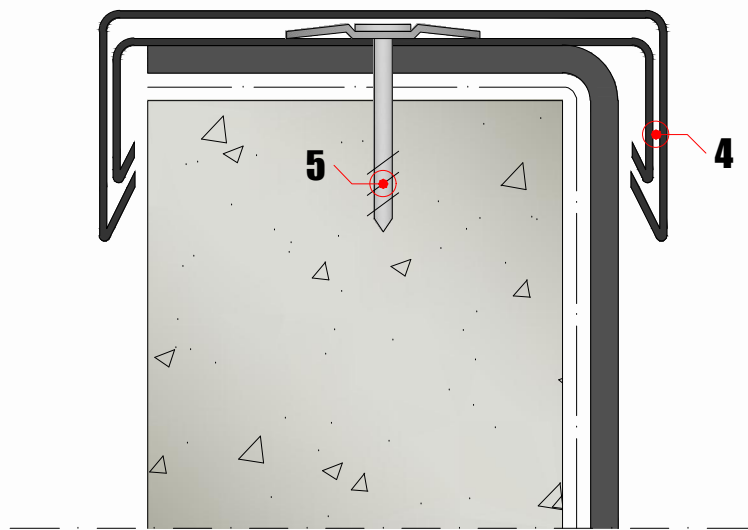

"Overflow" drains**B 02/6**

1. "Overflow drain"

2. Mechanical fixing

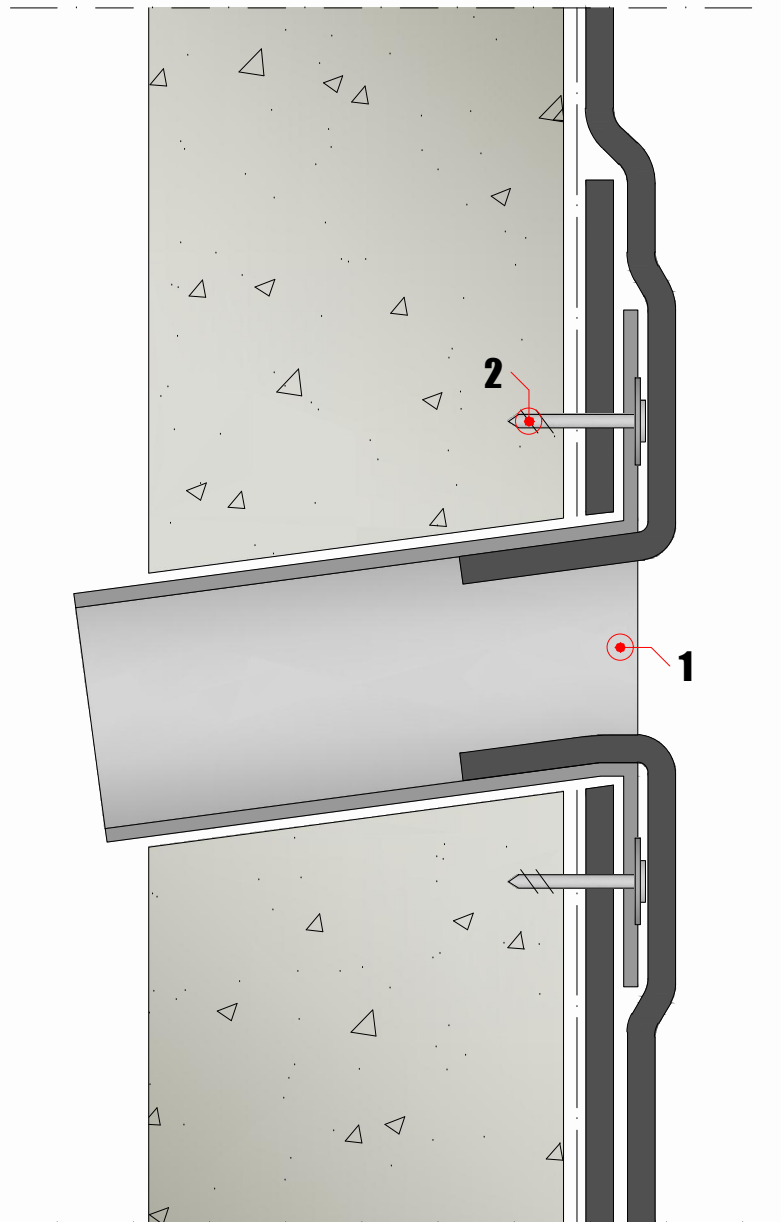

Skylights

B 02/7

1. Metal support	4. Bracket
2. Theraml insulation	5. Skylight
3. Windproof tape	

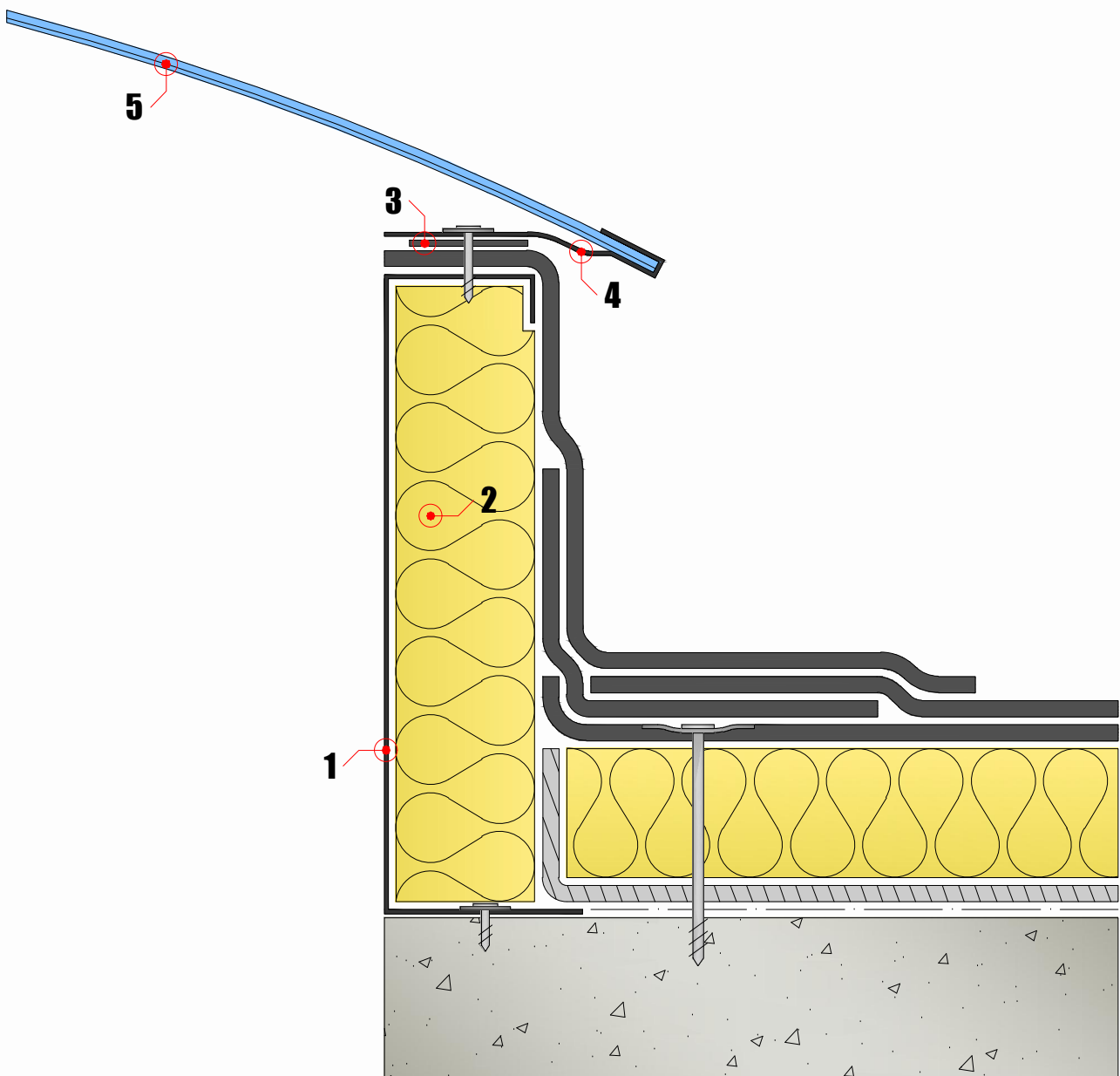

Expansion joint

B 02/8

1. Pontage

3. Sealing band-membrane

2. Flexible element

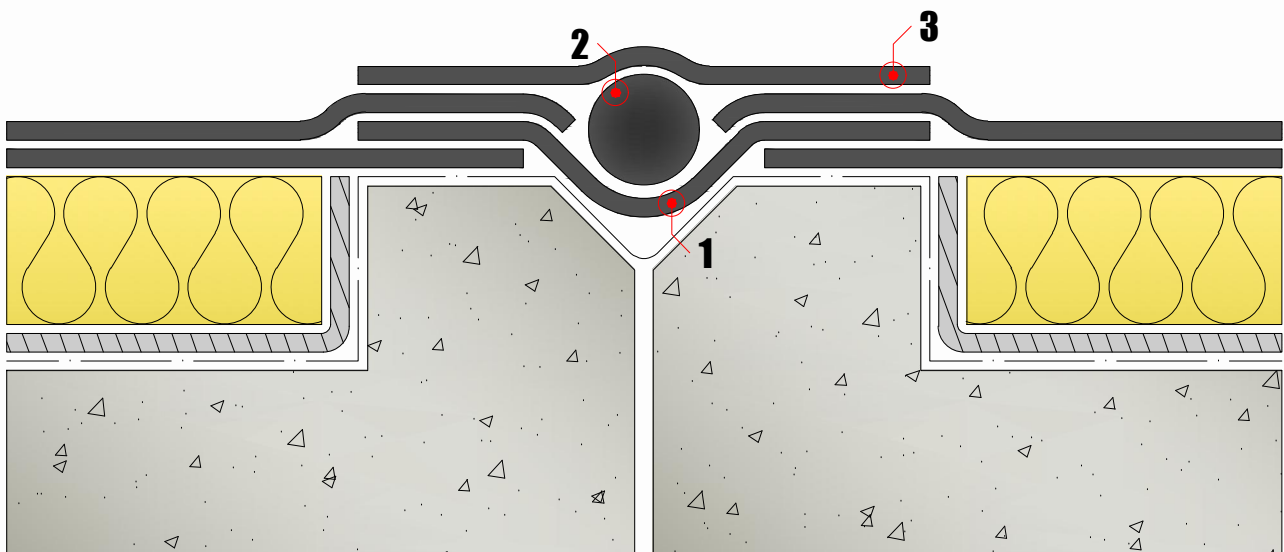

Access thresholds

B 02/9

1. Base

3. Doorstep

2. Floor

4. Door

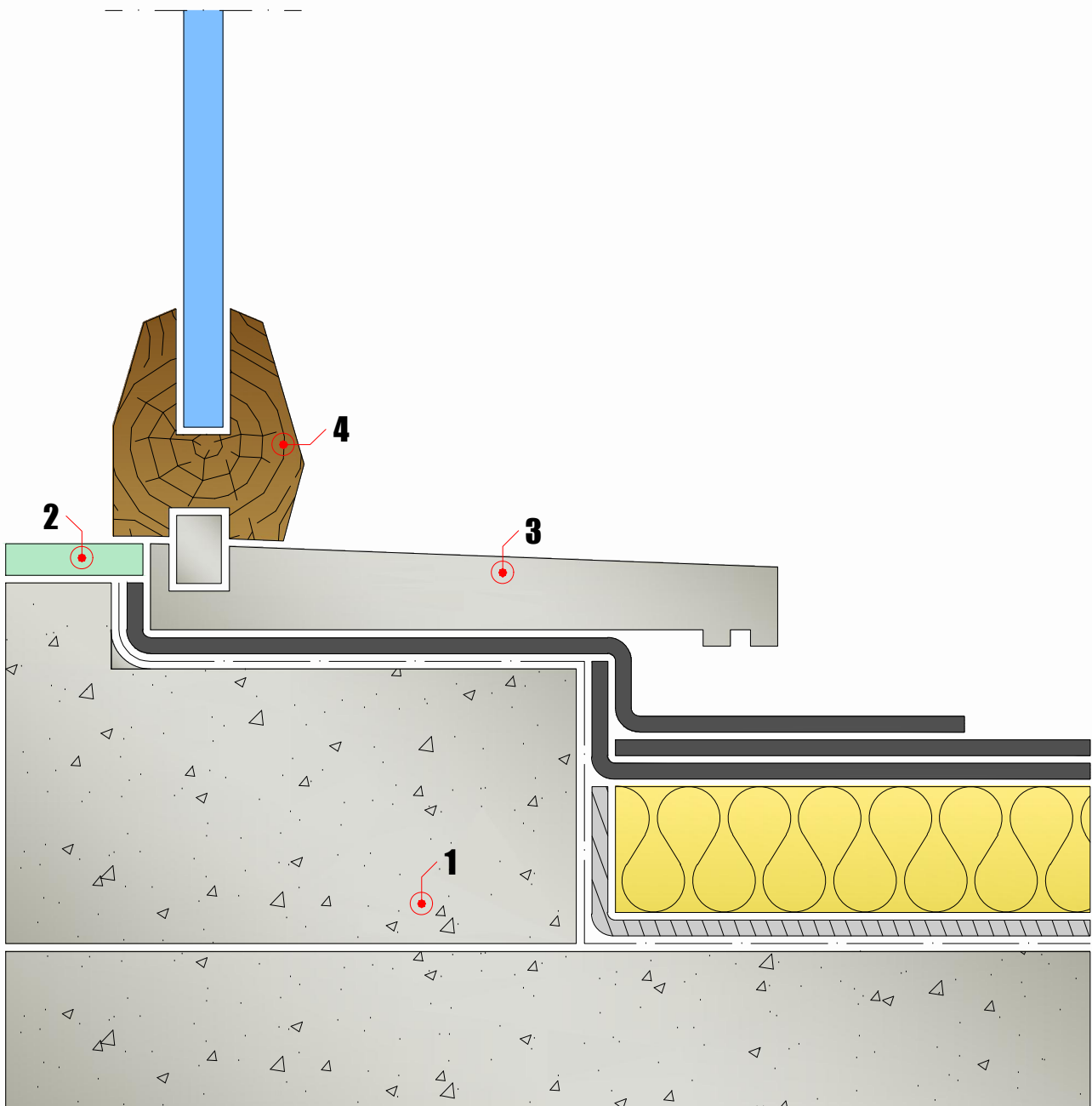

Sectoring

B 02/10

Step 1 - Sector sealing

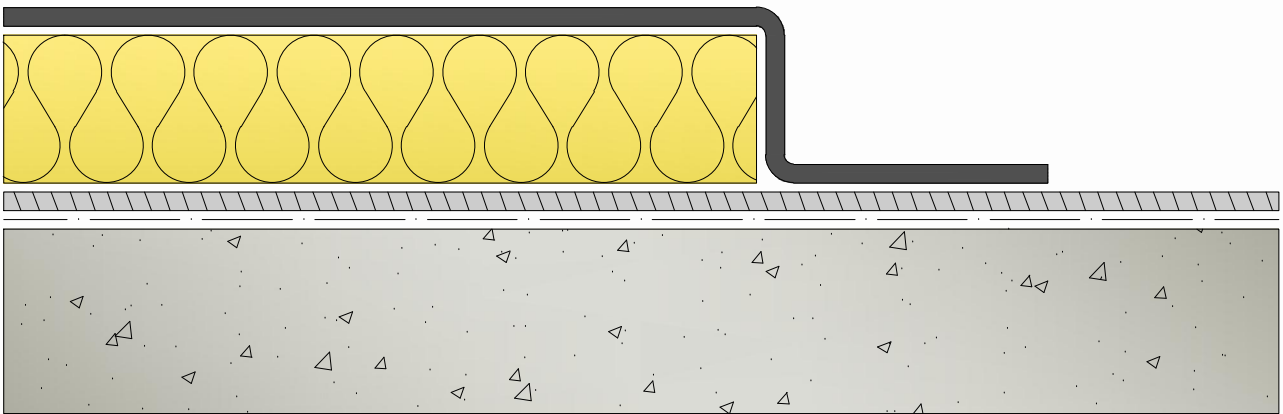

Step 2 - Continuation

